

TALARIA

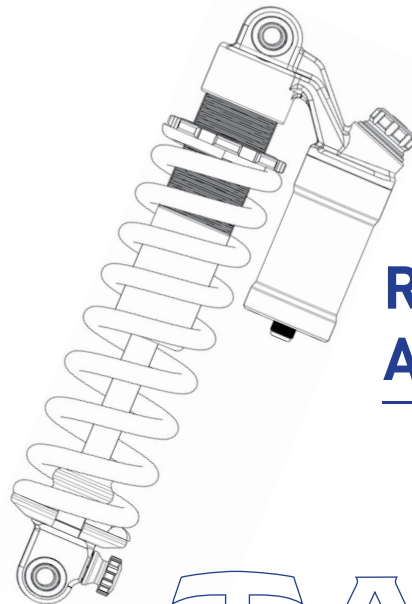

REAR SHOCK ABSORBER USER MANUAL

* Copyright TALARIA® 2023 all rights reserved



REAR SHOCK ABSORBER USER MANUAL

TALARIA

Thank you very much for choosing TALARIA-SUSPENSION shock absorber. It will always be your trustworthy partner! For your safe driving with full enjoyment of the ride which is brought by TALARIA-SUSPENSION shock absorber, please read the Manual carefully before use, and keep it properly in case of need.

We sincerely hope that you will make any valuable comments and suggestions on the design, use, performance, quality and after-sales service of TALARIA-SUSPENSION products.

TALARIA-SUSPENSION is willing to provide you with more professional shock absorbers and more sophisticated service!

The following contents are included in the Manual

- ◆ 1. Advice for safe use
- ◆ 2. Product appearance and accessories
- ◆ 3. Product features and functions
- ◆ 4. Description of damping adjustment, spring preload adjustment and air pressure gasbag
- ◆ 5. Installation precautions
- ◆ 6. Product maintenance
- ◆ 7. Warranty and after-sales service terms

To improve the product performance, we reserve the right to change the product without advance notice. If the actual picture is not in conformity with the product, please take the actual product as the criterion.

◆ 1. Advice for safe use

- 1.1 The rear shock absorber is one of the most important parts of the vehicle, which directly affects the stability of the vehicle. Before the product is used, please read the Manual carefully. Any failure to comply with the Manual will result in product failure, damage, property loss or personal injury. TALARIA-SUSPENSION is not responsible for these damages or injuries.
- 1.2 The installation and maintenance of the shock absorption system requires expertise, tools and experience. It is recommended to allow your vehicle dealer or authorized TALARIA-SUSPENSION service center to help you install and maintain it.
- 1.3 Do not make any changes to any accessories of your shock absorption system.
- 1.4 You shall learn to drive it within your capability. Any uncontrolled driving will damage your damping system and affects its service life.
- 1.5 After the product is installed, a low speed test is required to ensure the stability of the vehicle. Be sure to drive on a safe road and take approximate safety measures.
- 1.6 The suspension system or accessories of the vehicle shall be always checked for deformation, bending, cracking, or other damages. If the shock absorber has the abnormal sounds, uneven functions or any oil leakage, please immediately stop using and deliver the product to the TALARIA-SUSPENSION service center.

◆ 2. Product appearance and accessories (as shown in Fig. 1)

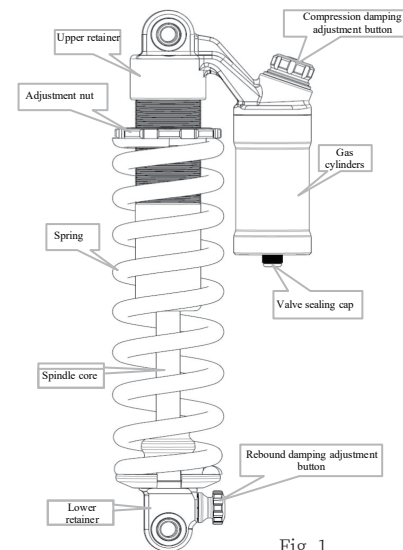
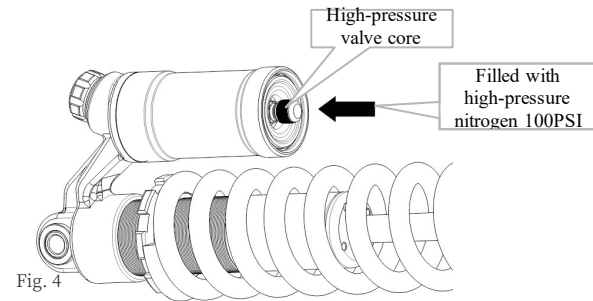
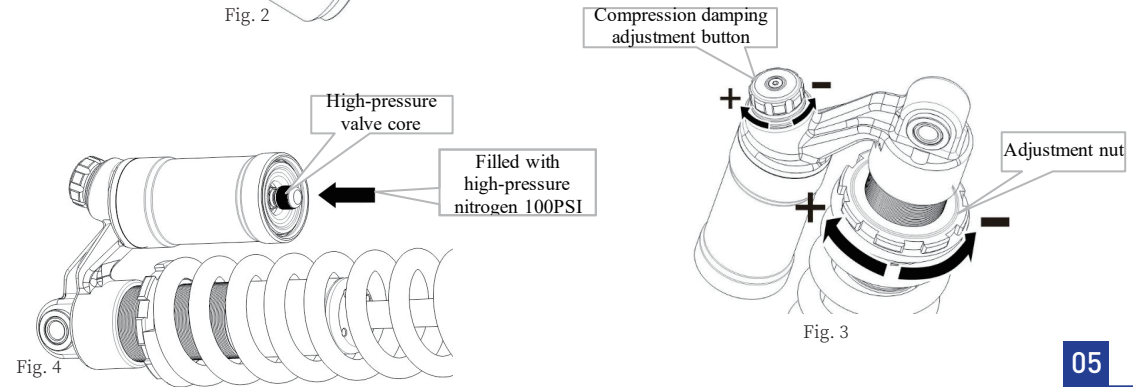
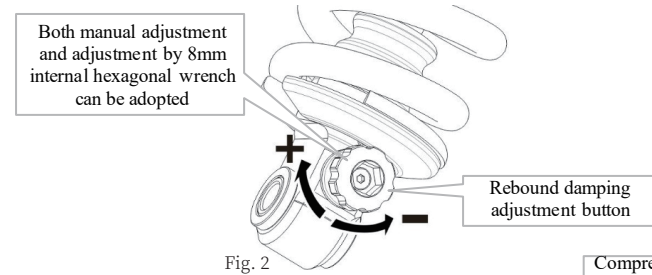

Fig. 1

◆ 3. Product features and functions

- 3.1 The rear shock absorber is a kind of lightweight high-strength shock absorber, which is designed and manufactured by TALARIA-SUSPENSION specially for the downhill bike. Its design features spring support, air pressure assistance and hydraulic damping.
- 3.2 A hydraulic damping system with an airbag is provided inside the rear shock absorber. To be specific, under the support of pressure generated by the high-pressure airbag in the fixed external cylinder on the rear shock absorber, the reciprocating piston and valve assembly form a more efficient damping system in the hydraulic oil, so as to inhibit the vibration and impact caused by vehicle acceleration and deceleration and road bumps. Special low-freezing, low-designation and high-quality oil for the wear-resistant shock absorber is adopted for the interior of the damper to ensure the damping stability.
- 3.3 The spring wound with a high-strength alloy spring wire is installed outside the rear shock absorber to support the weight of the rear section of the vehicle, with safety and reliability.
- 3.4 The rear shock absorber features adjustable compression damping, rebound damping and spring preload, and is equipped with a high-pressure airbag component, making your vehicle more useful.



◆ 4. Damping and spring preload adjustment and air pressure airbag

4.1 The rear shock absorber has the following external adjustment functions:

- A. Rebound damping adjustment;
- B. Compression damping adjustment;
- C. Spring preload adjustment;
- D. Setting of airbag inflation.

4.2 Rebound damping adjustment

- A. As shown in Fig. 2, manually turn the red rebound adjustment button on the lower retainer of the rear shock absorber to adjust the rebound damping.
- B. The clockwise turning of the red rebound adjustment button can increase the rebound damping, so that the rear shock absorber slows down during rebounding. The counterclockwise turning of the red rebound adjustment button can reduce the rebound damping, so that the rear shock absorber accelerates during rebounding.
- C. The rebound adjustment range is 12 segments. Generally, the red rebound adjustment button is adjusted clockwise to the maximum, and then adjusted counterclockwise to the required segment. The adjustment strength shall be moderate. The adjustment shall be immediately stopped if resistance occurs, and the adjustment strength cannot exceed the limit of the adjustment screw.
- D. The rebound damping can be properly set according to the weight, habit and road conditions of the rider:
 - a. While riding on a mountain road or curved road, rotate clockwise the rebound adjustment screw and make the front shock absorber rebound slowly in order to reduce the shaking.
 - b. While riding in a city or the bad road, rotate anti-clockwise the rebound adjustment screw and make the front shock absorber rebound quickly to reduce the hard sense.

4.3 Compression damping adjustment

- A. As shown in Fig. 3, manually turn the blue compression adjustment button on the upper retainer of the rear shock absorber to adjust the compression damping.
- B. The clockwise turning of the blue compression adjustment button can increase compression damping, so that the rear shock absorber hardens during pushing. The counterclockwise turning of the blue compression adjustment button can reduce compression damping, so that the rear shock absorber softens during pushing.
- C. The compression adjustment range is 18 segments. Generally, the blue compression adjustment button is adjusted clockwise to the maximum, and then adjusted counterclockwise to the required segment. The adjustment strength shall be moderate. The adjustment shall be immediately stopped if resistance occurs, and the adjustment strength cannot exceed the limit of the adjustment screw.
- D. The compression damping can be properly set according to the weight, habit and road conditions of the rider:
 - a. While riding on a flat road, rotate the compression adjustment screw clockwise to the direction of H, so as to increase the damping and the stability of the driving.
 - b. When the load is increased, the compression damping can be properly increased to avoid the shock absorber's bottoming.
 - c. When the vehicle body goes down too fast or shakes too much during turning, the compression damping can be increased properly.
 - d. While riding on a bad road, rotate the compression adjustment screw anti-clockwise to reduce the damping, so as to improve riding comfort.
 - e. When the shock absorber is subsided slowly or hardened by continuous bad road running, the compression pressure can be properly reduced when the vehicle body bounces.

4.4 Spring preload adjustment

- A. As shown in Fig. 3, rotate the spring adjustment nut forward and reversely with a customized hook wrench, so that the spring preload height changes to adjust the shock absorption support.
- B. The clockwise turning of the spring preload adjustment button can increase the damping support. The counterclockwise turning of the spring preload adjustment button can reduce the damping support.
- C. The pound value of the spring is 550LBS, the total spring length is 180mm, and the adjustable preload height is 0-10mm.

4.5 Setting of airbag inflation

As shown in Fig. 4, the airbag inflation pressure of this product is set at 100PSI

◆ 5. Installation precautions:

- 5.1 A. In order to make the shock absorber operate smoothly, please check whether the widths of upper and lower retainers of the rear shock absorber are consistent with the open gear widths of the frame and rear rocking frame, so as to ensure the rear shock absorber installed on the bike still can freely rotate.
- B. The locking torque of installation screws on upper and lower retainers of the rear shock absorber shall be within the set installation range, so as to avoid riding safety hazards caused by screw loosening or shedding.

◆ 6. Product maintenance

- 6.1 The service life of the shock absorber is determined based on many considerations, including road conditions, and the weight, driving habits and use strength of the rider. The impact beyond the limit of shock absorption, irregular fall of the bike, improper use or rough use can reduce the service life of the product.
- 6.2 Irregular or incorrect maintenance will cause damage to oil seals, self-lubricating bearings, dust seals, main pipes and other components, resulting in oil leakage or motion retardation.
- 6.3 If riding the muddy road, please clean the shock absorber as soon as possible, especially the sediments attached to the spindle core and the main tube, to avoid oil leakage from accelerating damage to the lip of the oil seal due to the long-term residue of sediments.
- 6.4 After riding 5000 km, please remove the shock absorber for inspection, repair and maintenance;

◆ 7. Warranty and after-sales service terms

7.1 General

- A. Meaning of warranty: if the HTW-SUSPENSION shock absorber that is qualified according to the technical standard has any quality problems caused the material or workmanship during the warranty period, our company will be responsible for the problem solving;
- B. Warranty period: six months from the date of sale.
- C. Warranty principle: the maintenance is based on the adjustment and repair.

7.2 Scope and regulation of warranty

- A. We guarantee the quality of the shock absorber: If the shock absorber purchased from us is found to have impact on the users due to materials or poor workmanship within three months from the date of purchase, it will be repaired or changed for free.
- B. The warranty service will not be provided for the following cases. However, due to the principle of responsibility for user, the service of repair will be provided, and the fee of parts and labor will be charged accordingly.
 - a. Beyond the specified period (according to the valid invoice);
 - b. Damage caused by accident or abnormal use, such as acrobatics, bounce, and fall;
 - c. Use, maintenance and operation not according to the requirements in the Manual;
 - d. The fault caused by the normal using abrasion of parts and long-time aging (such as the natural fading of oil, oil seal, dust seal, self-lubricating bearing and parts surface, etc.);
 - e. Damage caused by overhaul by self, modification or using non HTW-SUSPENSION components;
 - f. Damaged caused by natural disaster and man-made calamity or the irresistible force factor;

- C. In addition, TALARIA-SUSPENSION will not afford transportation cost and loss of working time due to maintenance, as well as compensation for inconvenience use or unavailable use during maintenance.

If you have any questions, please consult your dealer or the HTW-SUSPENSION after-sales service department.

TALARIA-SUSPENSION has the right of final explanation for the Manual, which is subject to change without notice.